

JET

JWBS-12

WOODWORKING BANDSAW

708901M

230/50/1

**PARTS LIST
ERSATZTEILLISTE
LISTE DE PIECES**

WMH Tool Group AG

Bahnstrasse 24, CH – 8603 Schwerzenbach

www.wmhtoolgroup.ch; info@wmhtoolgroup.ch

Tel +41 (0) 44 806 47 48

Fax +41 (0) 44 806 47 58

708901M 01 / 05



Breakdown for JWBS-12

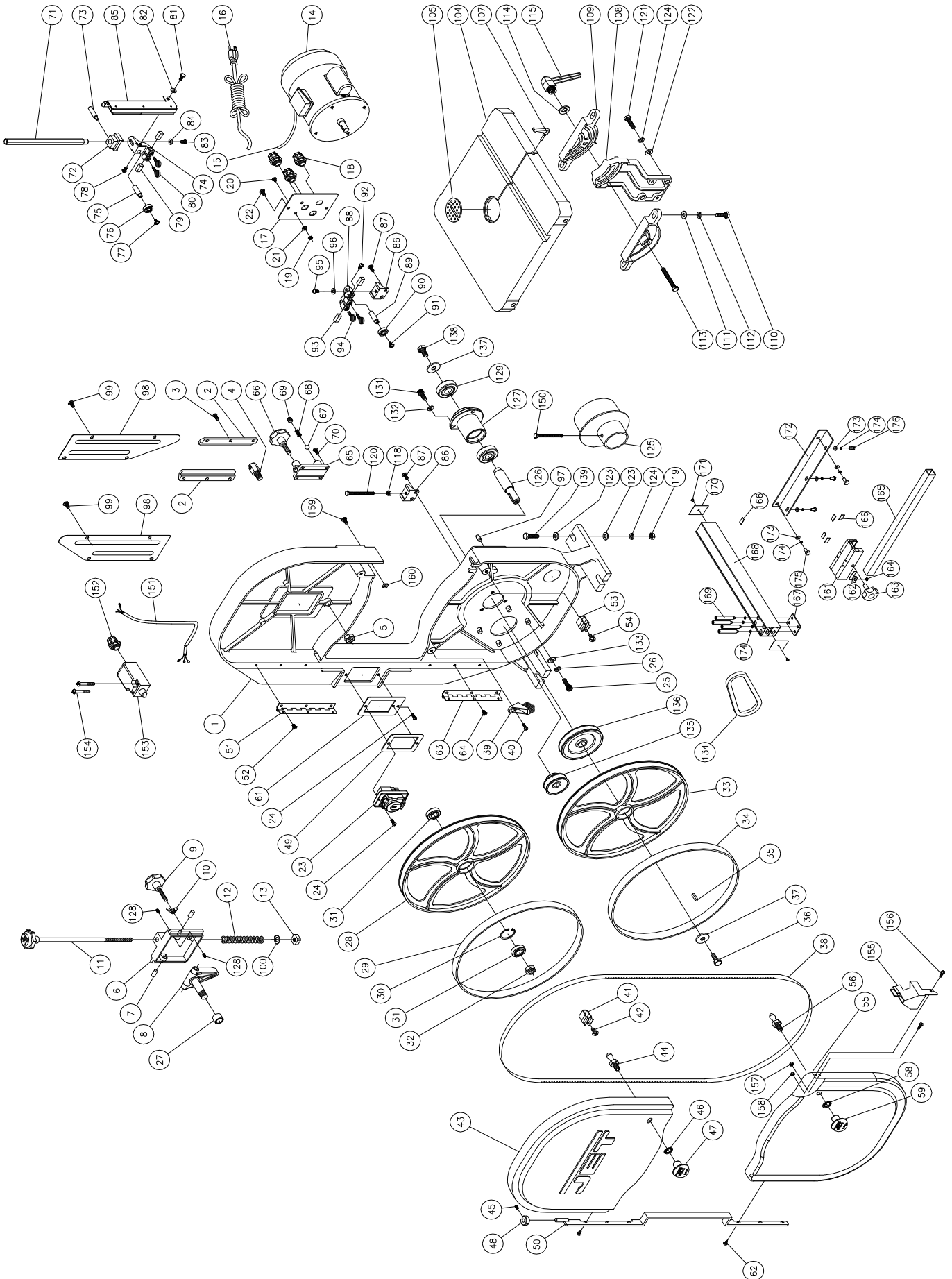

Parts List for the JWBS-12

Index No.	Part No.	Description	Size	Qty.
1	JWBS12-001E	Band Saw Frame		1
2	120002	Guide Bracket		2
3	TS-1534042	Pan Head Bolt	M6 x 12	6
4	120003	Stud		1
5	TS-1540083	Nut	M12 x 1.25	1
6	100016A	Upper Wheel Sliding Bracket		1
7	100021	Steel Pin		2
8	AB100019	Shaft Hinge		1
9	990652	Knob		1
10	NW080000	Wing Nut	M8	1
11	AB120020	Blade Adjusting Screw		1
12	100015A	Coil Spring		1
13	NS101700	Square Nut	M10	1
14	JWBS12-014E	Motor 230/50/1	230V, 50Hz, CE	1
15	JWBS12-015E	Motor Cord (H05VV-F)	3G x 1.0mm ²	1
16	JWBS12-016E	Power Cord (H05RN-F)	3G x 1.0mm ²	1
17	JWBS12-017E	Cord Locating Plate		1
18	JWBS12-018E	Strain Relief	PG9	3
19	TS-1540031	Nut	M5	2
20	TS-1533052	Pan Head Bolt w/ Flange	M5 x 8	2
21	WE05000	Gear Washer	M5	2
22	TS-1534032	Pan Head Bolt w/ Flange	M6 x 8	2
23	JWBS12-023E	Magnetic Switch 230/50/1	KJD-12	1
24	TS-1533052	Pan Head Bolt	M5 x 16	3
25	TS-1515031	Hex Socket Cap Screw Bolt	M8 x 25	4
26	TS-1551041	Lock Washer	M8	4
27	360085	Bushing		1
28	120004	Upper Wheel		1
29	120005	Wheel Tire		1
30	RR350000	Retaining Ring	R35	1
31	BB-6202ZZ	Ball Bearing		2
32	TS-1540081	Nut	M12	1
33	120006	Lower Wheel		1
34	120005	Wheel Tire		1
35	KP050520	Key	5 x 5 x 20	1
36	SH080402	Hex Cap Bolt (reverse thread)	M8 x 20	1
37	TS-1550051	Flat Washer	M8	1
38	709392	Saw Blade (6 T.P.I.)	1/4x82 x .020	1
39	170507	Brush		1
40	TS-1533032	Pan Head Screw	M5 x 10	
41	JWBS12-041E	Catch		1
42	TS-1533042	Pan Head Bolt	M5 x 12	1
43	120007W	Upper Wheel Cover		1
44	170080	Stud Latch		1
45	ST-1522011	Set Screw	M5x5	1
46	WI080000	Gear Washer (internal)	M8	1
47	JWBS12-047E	Knob		1
48	JWBS12-048E	Switch Bushing		1
49	JWBS12-049E	Spong Pad		1
50	JWBS-050E	Conect Plate		1
51	120009	Hinge		1
52	SN050200	Countersunk Bolt	M5 x 10	3
53	150079	Catch		1
54	TS-1533042	Pan Head Bolt	M5 x 12	1
55	JWBS12-055E	Lower Wheel Cover		1
56	JWBS12-056E	Stud Latch		1
58	WI080000	Gear Washer (internal)	M8	1
59	JWBS12-059E	Knob		1
61	JWBS12-61E	Switch Plate		1
62	ST049300	Tapping Screw	M4 x 12	6

63.....	120009.....	Hinge.....	1
64.....	TS-1533042.....	Pan Head Screw..... M5 x 10	3
65.....	120010.....	Guide Post Bracket.....	1
66.....	990651.....	Knob.....	1
67.....	SB-5/16.....	Steel Ball.....	1
68.....	150099.....	Spring.....	1
69.....	TS-1525011.....	Set Screw..... M10 x 10	1
70.....	TS-1534042.....	Pan Head Screw..... M6 x 12	4
71.....	120011.....	Guide Post.....	1
72.....	120012.....	Upper Support Bracket Post.....	1
73.....	JWBS12-073E	Handle.....	1
74.....	120013.....	Bracket.....	1
75.....	120014.....	Spacing Sleeve.....	1
76.....	BB-608ZZ.....	Ball Bearing.....	1
77.....	SF059100.....	Pan Head Bolt w/ Flange..... M5 x 6	1
78.....	TS-1482021.....	Hex Cap Bolt..... M6 x 12	1
79.....	KP080818.....	Guide Block..... 8 x 8 x 18	2
80.....	SU069300.....	Thumb Bolt..... M6 x 12	2
81.....	TS-1514011.....	Hex Socket Cap Bolt..... M6 x 12	1
82.....	TS-1550041.....	Flat Washer..... M6	1
83.....	TS-1503031.....	Hex Cap Bolt..... M6 x 12	1
84.....	TS-1550041.....	Flat Washer..... M6	1
85.....	JWBS12-085CE	Upper Wheel Blade Guard(A.S.M).....	1
86.....	120015.....	Lower Support Bracket Post.....	1
87.....	TS-1534042.....	Pan Head Bolt w/ Flange..... M6 x 12	4
88.....	120013.....	Bracket.....	1
89.....	120014.....	Spacing Sleeve.....	1
90.....	BB-608ZZ.....	Ball Bearing.....	1
91.....	SF059100.....	Pan Head Bolt w/ Flange..... M5 x 6	1
92.....	TS-1534042.....	Pan Head Screw..... M6 x 12	1
93.....	KP080818.....	Guide Block..... 8 x 8 x 18	2
94.....	SU069300.....	Thumb Bolt..... M6 x 12	2
95.....	TS-1514011.....	Hex Socket Cap Bolt..... M6 x 12	1
96.....	TS-1550041.....	Flat Washer..... M6	1
97.....	150031.....	Pin.....	2
98.....	120025W.....	Rear Plate.....	2
99.....	SF069300	Pan Head Screw w/ Flange..... M6 x 8	8
100.....	JWBS12-100E	Pointer.....	1
104.....	JWBS12-104E	Table.....	1
105.....	JWBS12-105E	Table Insert.....	1
107.....	JWBS12-106E	Table Pin.....	1
108.....	120019.....	Trunnion Bracket.....	1
109.....	120022.....	Trunnion.....	2
110.....	TS-1490031	Hex Cap Bolt..... M8 x 20	4
111.....	TS-1550051.....	Flat Washer..... M8	4
112.....	TS-1551061.....	Lock Washer..... M8	4
113.....	SH081400.....	Hex Cap Bolt..... M8 x 70	1
114.....	TS-1550051.....	Flat Washer..... M8	1
115.....	120027.....	Lock Handle Assembly.....	1
118.....	TS-1540041.....	Nut..... M6	1
119.....	TS-1540061.....	Nut..... M8	4
120.....	SH061400.....	Hex Cap Bolt..... M6 x 70	1
121.....	TS-1490051.....	Hex Cap Bolt..... M8 x 30	2
122.....	TS-1550051.....	Flat Washer..... M8	2
123.....	TS-1550051.....	Flat Washer..... M8	8
124.....	TS-1551061.....	Lock Washer..... M8	6
125.....	JW1000.....	Adapter.....	1
126.....	120026.....	Main Shaft.....	1
127.....	120024W.....	Bushing.....	1
128.....	TS-1520031.....	Set Screw..... M5 x 10	2
129.....	BB-6203-2RS.....	Ball Bearing.....	2
131.....	TS-1515021.....	Socket Cap Bolt..... M8 x 20	3
132.....	TS-1551061.....	Lock Washer..... M8	3
133.....	TS-1550051.....	Flat Washer..... M8	4
134.....	VB-4L190.....	V-Belt.....	1
135.....	JWBS12-135E	Pulley.....	1
136.....	120028.....	Pulley.....	1

137	TS-1550051	Flat Washer	M8	1
138	TS-1490021	Hex Cap Bolt	M8 x 16	1
139	TS-1490061	Hex Cap Bolt	M8 x 35	4
150	TS-1490081	Hex Cap Bolt	M6 x 45	1
151	JWBS12-151E	Limmit Switch Cord		1
152	JWBS12-152E	Strain Relief	PG-11	1
153	JWBS12-153E	Limmit Switch	10A	1
154	SF040700	Pan Head Bolt W/flange	M4x35	2
155	JWBS12-155E	Lower Blade Guard		1
156	TS-1533052	Pan Head Bolt W/flange	M5x8	2
157	TS-1541011	Nylon Nut	M5	1
158	TS-1540031	Nut	M5	1
159	TS-1533052	Pan Head Bolt W/flange	M5x8	1
160	NS050800	Square Nut	M5	1
161	JWBS12-161E	Adjust Base		1
162	JWBS12-162E	Sping Piece		1
163	JWBS12-163E	Knob	M10x25	1
164	SF069200	Pan Head Bolt W/flange	M6x8	1
165	JWBS12-165E	Square Tube		1
166	JWBS12-166E	Pad		5
167	JWBS12-167E	Bracket		1
168	JWBS12-168E	Support Tube		1
169	JWBS12-169E	Step Screw	M6x13	4
170	JWBS12-170E	Guard Piece		2
171	ST039200	Tapping Screw	3.5x8	2
172	JWBS12-172E	Angle Steel		1
173	TS-1550041	Flat Washer	M6	5
174	TS-1551041	Lock Washer	M6	9
175	TS-1482041	Hex Head Bolt	M6x20	2
176	TS-1482011	Hex Head Bolt	M6x10	3
	JWBS12-MFC	Motor Fan Cover (not shown)		1
	JWBS12-CC	Capacitor Cover (not shown)		1
	JWBS12-CAPE	Starting Capacitor (not shown)	200MFD,250VAC	1
	AH-12001	Hardware Kit (saw body)		1
	JWBS12-FHK	Hardware Kit (fence)		1

Stand Assembly

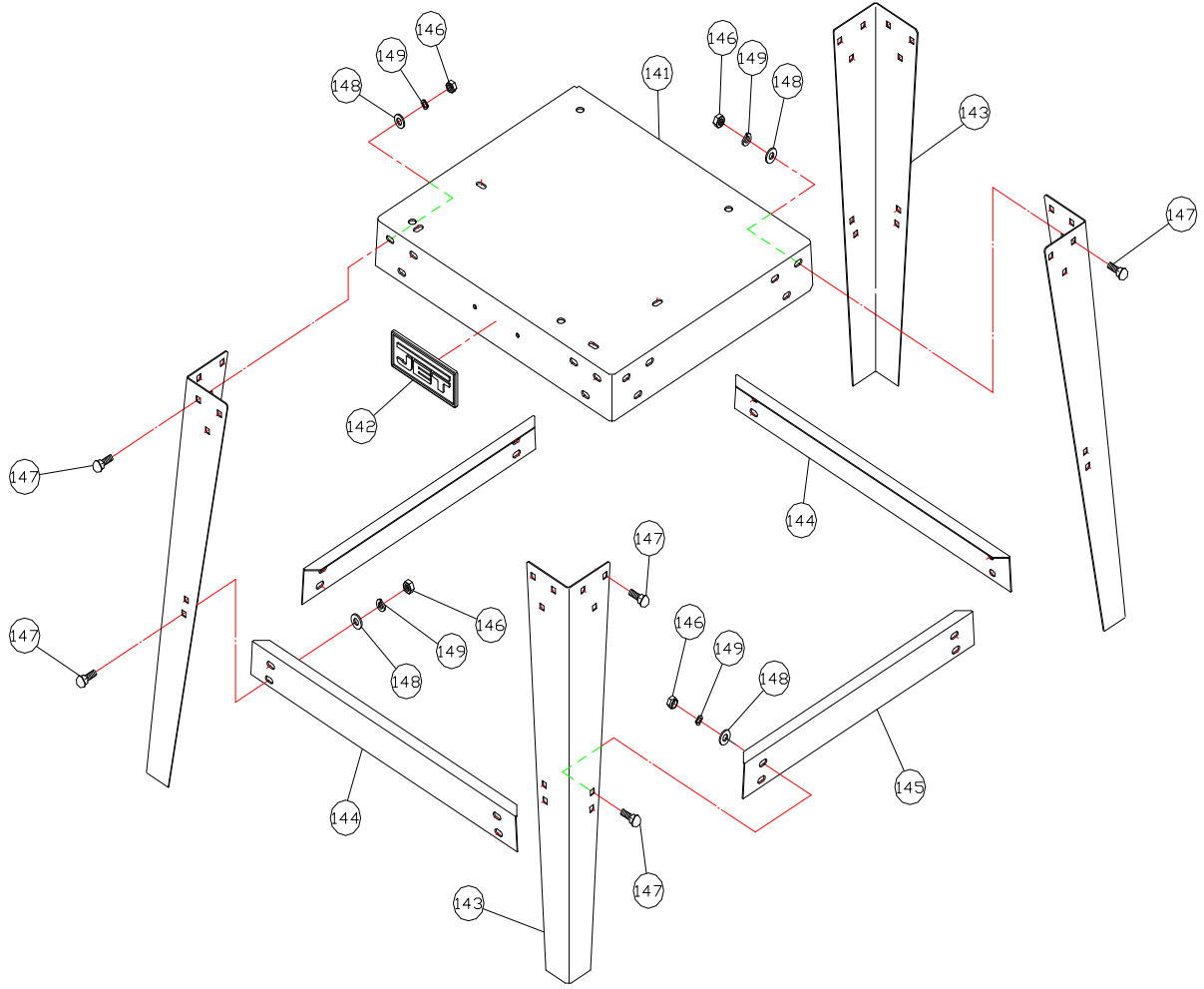

141.....	612049.....	Stand Top.....	1
142.....	120027.....	Plaque.....	1
143.....	150603.....	Support Leg.....	4
144.....	612050.....	Support Plate (long).....	2
145.....	612051.....	Support Plate (short).....	2
146.....	TS-1540061.....	Nut.....	M8.....40
147.....	SC089400.....	Carriage Bolt.....	M8 x 16.....40
148.....	TS-1550051.....	Flat Washer.....	M8.....40
149.....	TS-1551061.....	Lock Washer.....	M8.....40
.....	AH-61202K.....	Hardware Kit (stand assembly).....	1

JWBS-12

708901M

	colour of strands	Litzenfarben	couleur des cordons
BK	black	schwarz	noir
WH	white	weiß	blanc
BU	blue	blau	bleu
YE	yellow	gelb	jaune
RD	red	rot	rouge
BN	brown	braun	brun
GY	grey	grau	gris
GNYE	green-yellow	grün-gelb	vert-jaune
OG	orange	orange	orange
VT	violet	violett	violet

	meaning of symbol	Bedeutung der Zeichen	interprétation
M	motor	Motor	moteur
S	switch	Schalter	interrupteur
C	condenser	Kondensator	condensateur
E	electronic unit	Elektronik Einheit	unité électronique
F	fuse	Sicherung	fusible
RS	reversing switch	Drehrichtungsschalter	commu. droite/gauche
CS	centrifugal switch	Fliehkraftschalter	déclencheur centrifuge
OL	overload cut-off	Überlastschuttschalter	déclencheur surcharge
LS	limit switch	Positionsendschalter	micro

