

JET

JWS-2700 SINGLE SPINDLE MOULDER

1280102T...400/50/3

PARTS LIST

Walter Meier (Tool) AG
Tämperlistrasse 5
CH-8117 Fällanden
Switzerland
Phone +41 44 806 47 48
Fax +41 44 806 47 58
jetinfo.eu@waltermeier.com
www.jettools.com



P-1280102T 2010/06/25

Table Assembly

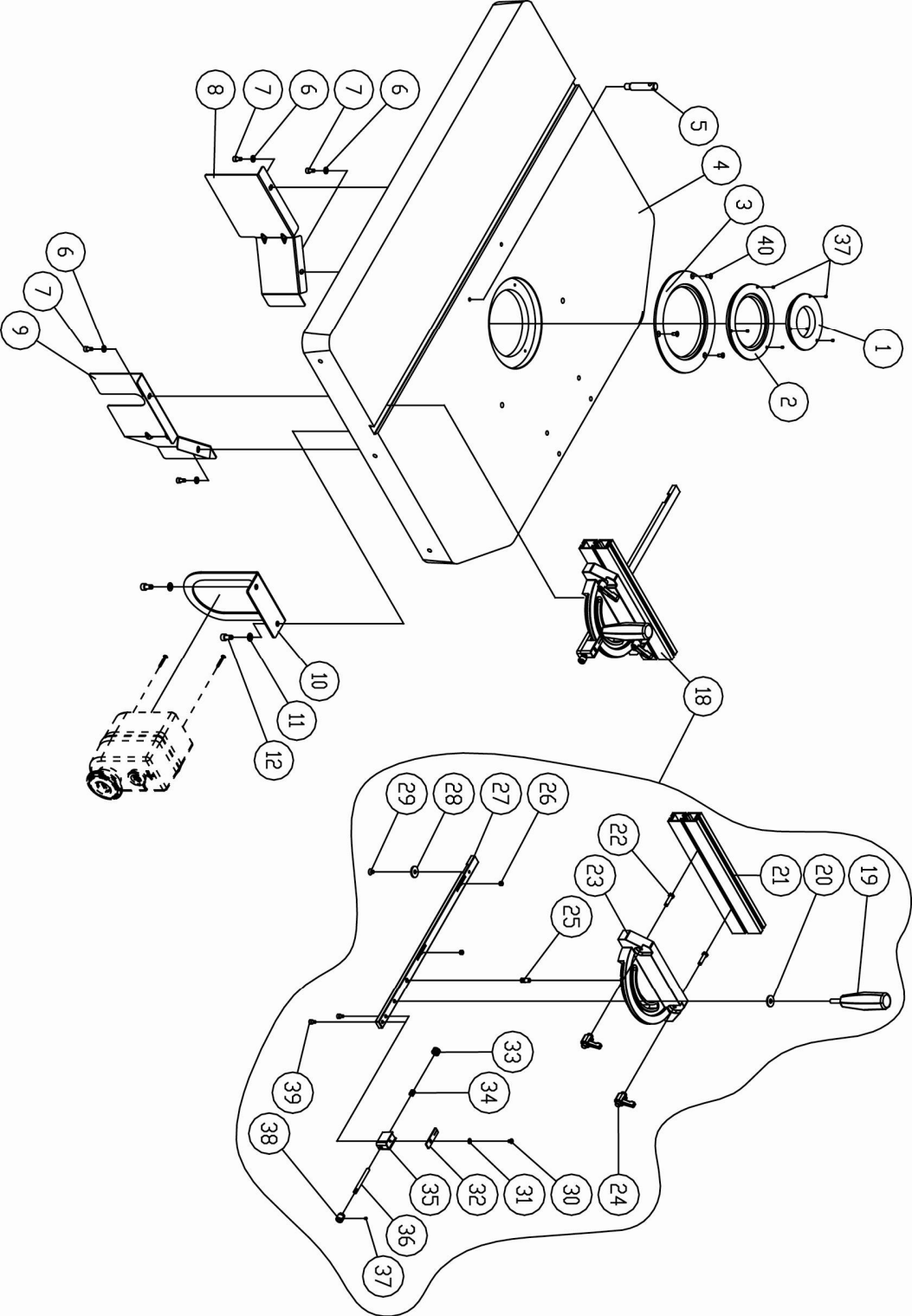
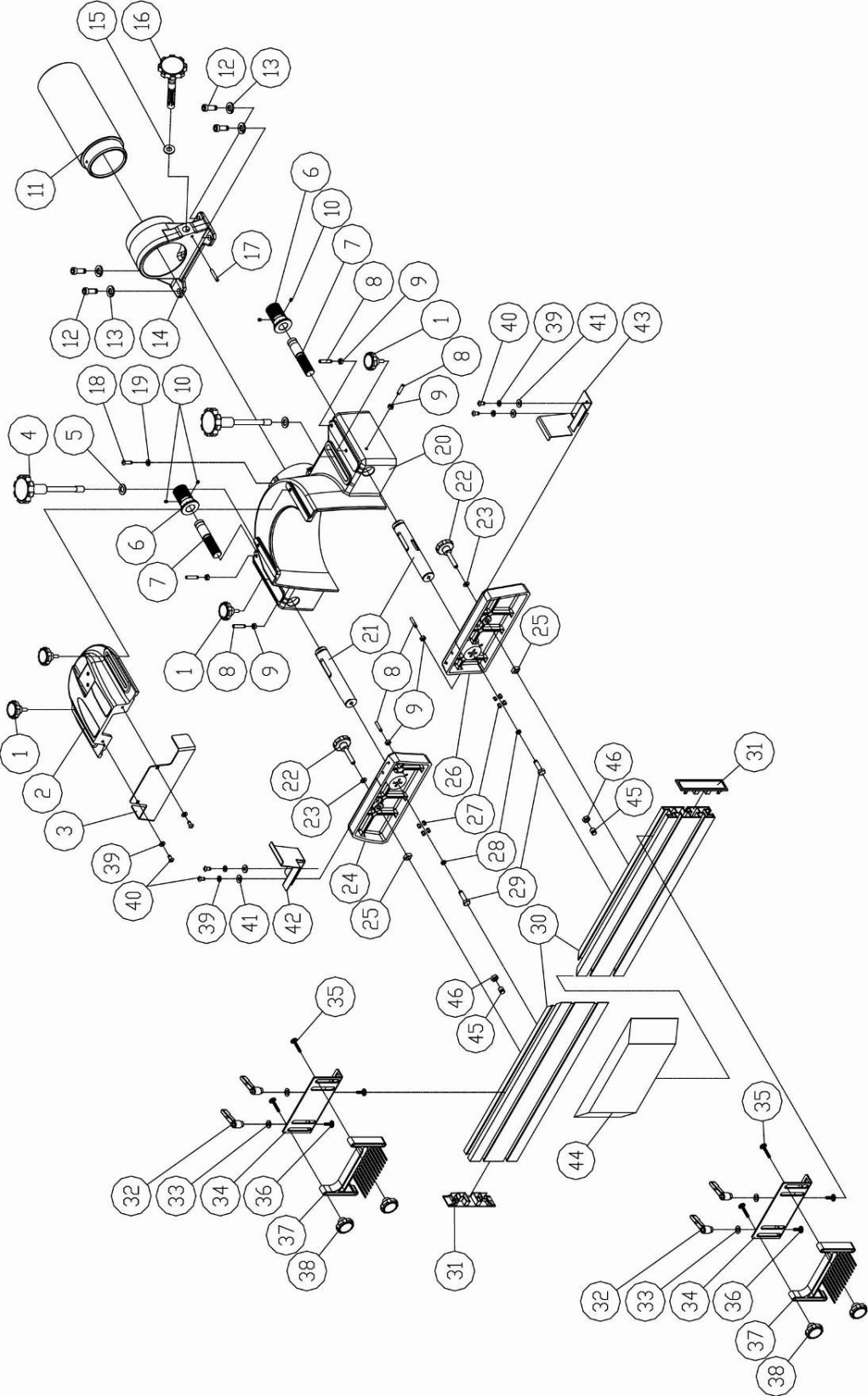

Table – Parts List

Index No.	Part No.	Description	Size	Qty
1	JWS2700-101	Insert Ring (Small)		1
2	JWS2700-102	Insert Ring (Mid)		1
3	JWS2700-103	Insert Ring (Big)		1
4	JWS2700-104	Table		1
5	JWS2700-105	Starting Pin		1
6	TS-2361061	Lock Washer	M6	4
7	TS-1503031	Hex Socket Cap Screw	M6-1.0P x 12	4
8	JWS2700-108	Dust Deflector (left)		1
9	JWS2700-109	Dust Deflector (right)		1
10	JWS2700-110	Switch Plate		1
11	TS-1550061	Flat Washer	M8	2
12	TS-1504041	Hex Socket Cap Screw	M8-1.25P x 20	2
18	1791789	Miter Gauge Assembly (Index #19 thru #39)		1
19	PM2000-340	Handle		1
20	TS-0680031	Flat Washer	5/16"	1
21	PM2000-342	Fence		1
22	TS-0050051	Hex Cap Screw	1/4"-20 x 1"	2
23	PM2000-323	Miter Gauge Body		1
24	PM2000-333	Locking Handle		2
25	PM2000-324	Pin		1
26	PM2700-126	Socket Set Screw	M8-1.25P x 5	2
27	PM2000-325	Miter Bar		1
28	PM2000-326	Guide Washer		1
29	PM2000-327	Flat Head Machine Screw	M6-1.0P x 9	1
30	TS-0810012	Round Head Screw	#10-24 x 1/4"	1
31	TS-1550031	Flat Washer	M5	1
32	PM2000-335	Pointer		1
33	PM2700-133	Gear		1
34	PM2000-336	Spring		1
35	PM2000-330	Support Base		1
36	PM2000-337	Gear Shaft		1
37	TS-1521011	Socket Set Screw	M4-0.7P x 4	7
38	PM2000-331	Knob		1
39	PM2000-329	Hex Socket Cap Screw	M5-0.8P x 8	2
40	TS-1513021	Socket Head Flat Screw	M5-0.8P x 12	3

Fence Assembly



Fence – Parts List

Index No.	Part No.	Description	Size	Qty
	JWS2700-FA	Fence Complete Assembly		1
1	JWS2700-201	Knob		4
2	JWS2700-202	Safety Guard Holder		1
3	JWS2700-203	Safety Guard		1
4	JWS2700-204	Lock Handle		2
5	JWS2700-205	Flat Washer	M13	2
6	JWS2700-206	Knob		2
7	JWS2700-207	Adjustment Leader		2
8	TS-1523071	Socket Set Screw	M6-1.0P x 25	6
9	TS-1540041	Hex Nut	M6-1.0P	6
10	JWS2700-210	Socket Set Screw	M5-0.8P x 5	4
11	JWS2700-211	Dust Chute		1
12	TS-1505031	Hex Socket Cap Screw	M10-1.5P x 25	4
13	TS-2361101	Lock Washer	M10	4
14	JWS2700-214	Bracket		1
15	TS-155010	Flat Washer	M16	1
16	JWS2700-216	Leader Knob		1
17	JWS2700-217	Spring Pin	• 5 x 32	1
18	JWS2700-218	Screw	M6-1.0P x 20	1
19	TS-2361061	Lock Washer	M6	1
20	JWS2700-220	Fence Body		1
21	JWS2700-221	Shaft		2
22	JWS2700-222	Lock Knob		2
23	JWS2700-223	Flat Washer	M8	2
24	JWS2700-224	Left Fence Plate		1
25	JWS2700-225	Nut	M8-1.25P	2
26	JWS2700-226	Right Fence Plate		1
27	TS-2276081	Socket Set Screw	M6-1.0P x 8	8
28	JWS2700-228	Bushing		2
29	TS-1490051	Hex Cap Screw	M8-1.25P x 30	2
30	JWS2700-230	Fence		2
31	JWS2700-231	End Cap		2
32	JWS2700-232	Lock Handle		4
33	TS-1550061	Flat Washer	M8	4
34	JWS2700-234	Bracket		2
35	JWS2700-235	Carriage Bolt	M5-0.8P x 30	4
36	JWS2700-236	Carriage Bolt	M5-0.8P x 16	4
37	JWS2700-237	Feather Board		2
38	JWS2700-238	Knob		4
39	JWS2700-239	Lock Washer	M6	6
40	JWS2700-240	Socket Head Button Screw	M6 x 1.0P x 12	6
41	JWS2700-241	Flat Washer	M6	4
42	JWS2700-242	Safety Guard (Left side)		1
43	JWS2700-243	Safety Guard (Right Side)		1
44	JWS2700-244	Wooden		1
45	TS-1525021	Socket Set Screw	M10 x 1.5P x 12	2
46	TS-2311101	Hex Nut	M10	2

Parts List and Assembly for the Fence Guard

Index No.	Part No.	Description	Size	Qty.
	JWS-34KX-FGA	Fence Guard Assembly		1
1	JWS-34KX-201	Main Bracket		1
2	JWS-34KX-202	Knob	M8 x 1.25p x 19	1
3	JWS-34KX-203	Guide Bar		1
4	JWS-34KX-204	Bracket		1
5	JWS-34KX-205	Fence		1
6	JWS-34KX-206	Plate		1
7	JWS-34KX-207	Socket Head Flat Screw	M5 x 0.8 x 10	1
8	JWS-34KX-208	Knob	M8 x 1.25p x 12	2
9	JWS-2700-209	Guide Bar		1
10	JWS-34KX-210	Spring Plate		1
11	JWS-34KX-211	Nail	• 4.8 x 7.4	2
12	JWS-34KX-212	End Cap		2
13	JWS-34KX-213	Push Stick		1
14	JWS-34KX-214	End Grip		1
15	JWS-34KX-215	Socket Set Screw w/ Steel ball	M8 x 1.25p x 15	2
16	JWS-34KX-216	Hex Nut	M8	2

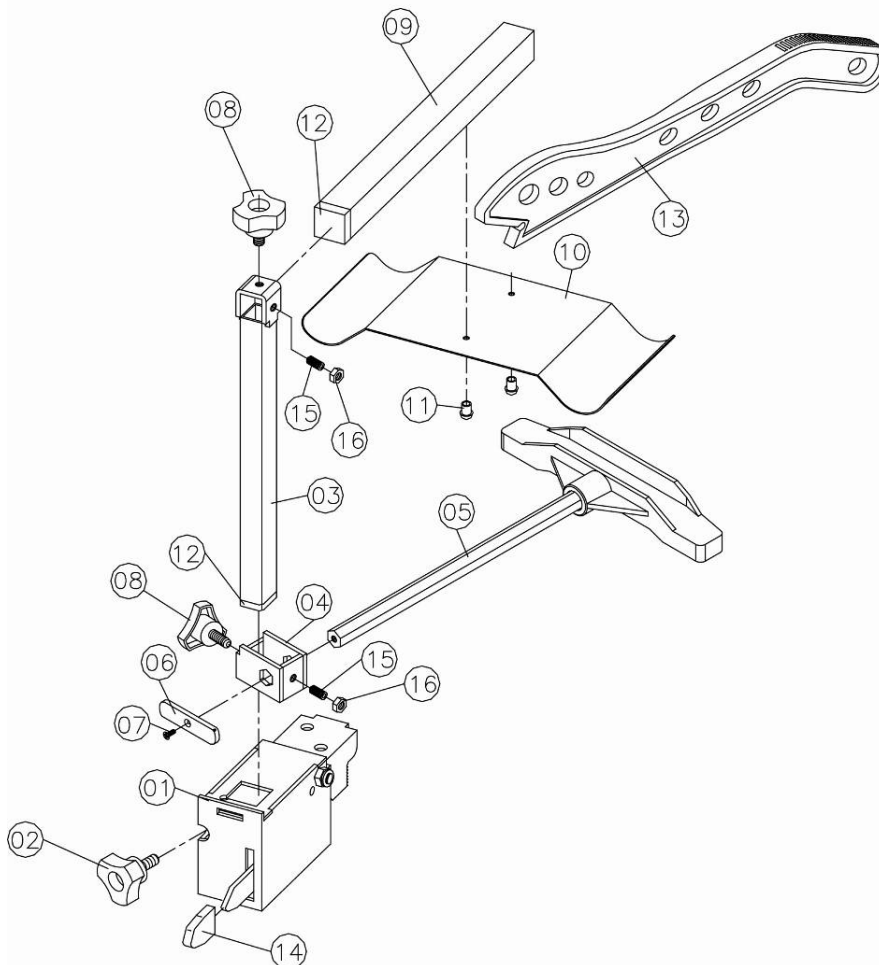

Parts List and Assembly for the Curved Guard

Index No.	Part No.	Description	Size	Qty.
.....	JWS-34KX-CGACurved Guard Assembly		1
1.....	JWS-34KX-301Dust Bracket Assembly		1
2.....	JWS-34KX-302Safety Shield Mount Assembly		1
3.....	JWS-34KX-303See through Guard		1
4.....	JWS-34KX-304Guide Plate Assembly		1

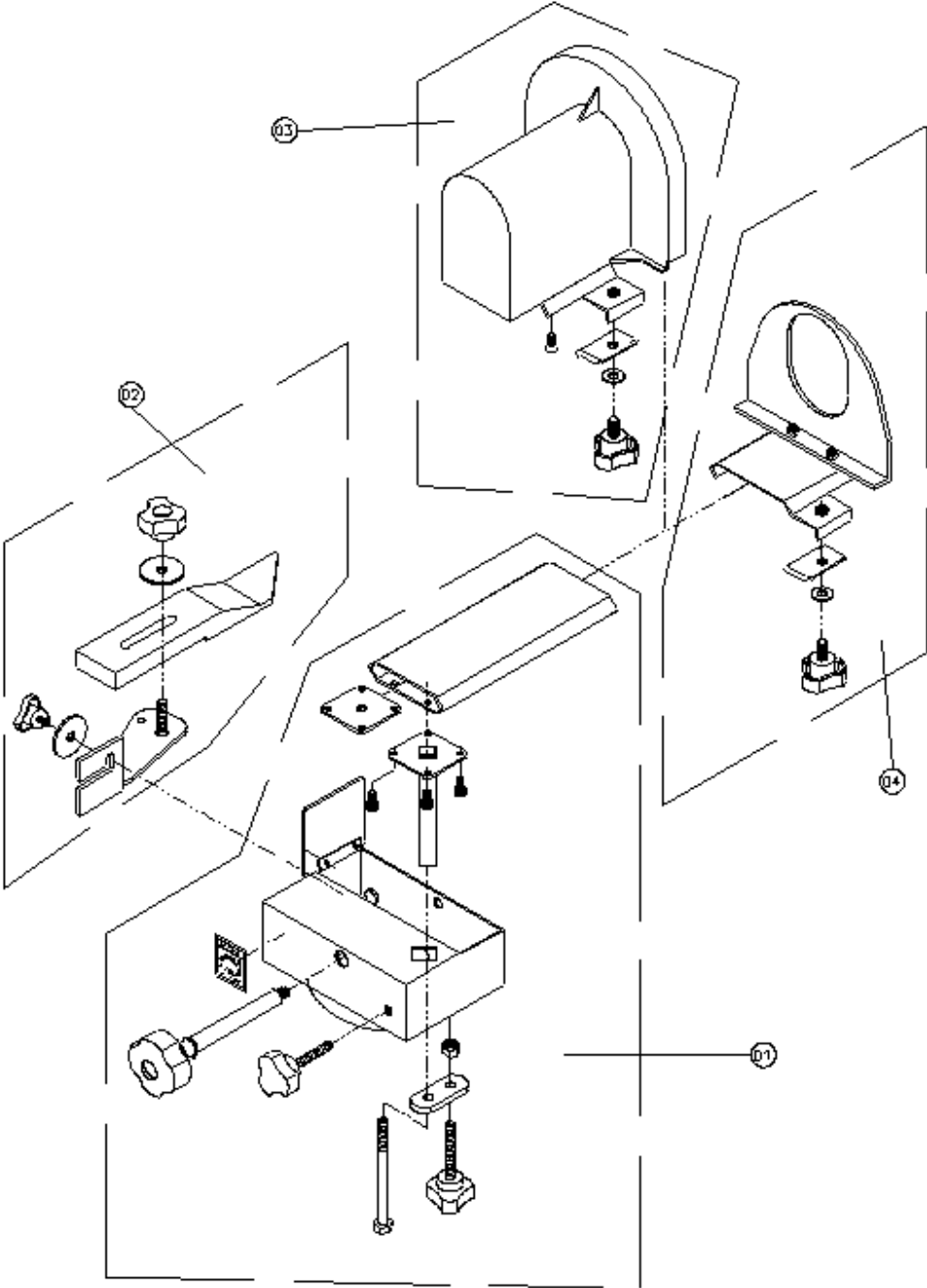

Frame and Motor Assembly

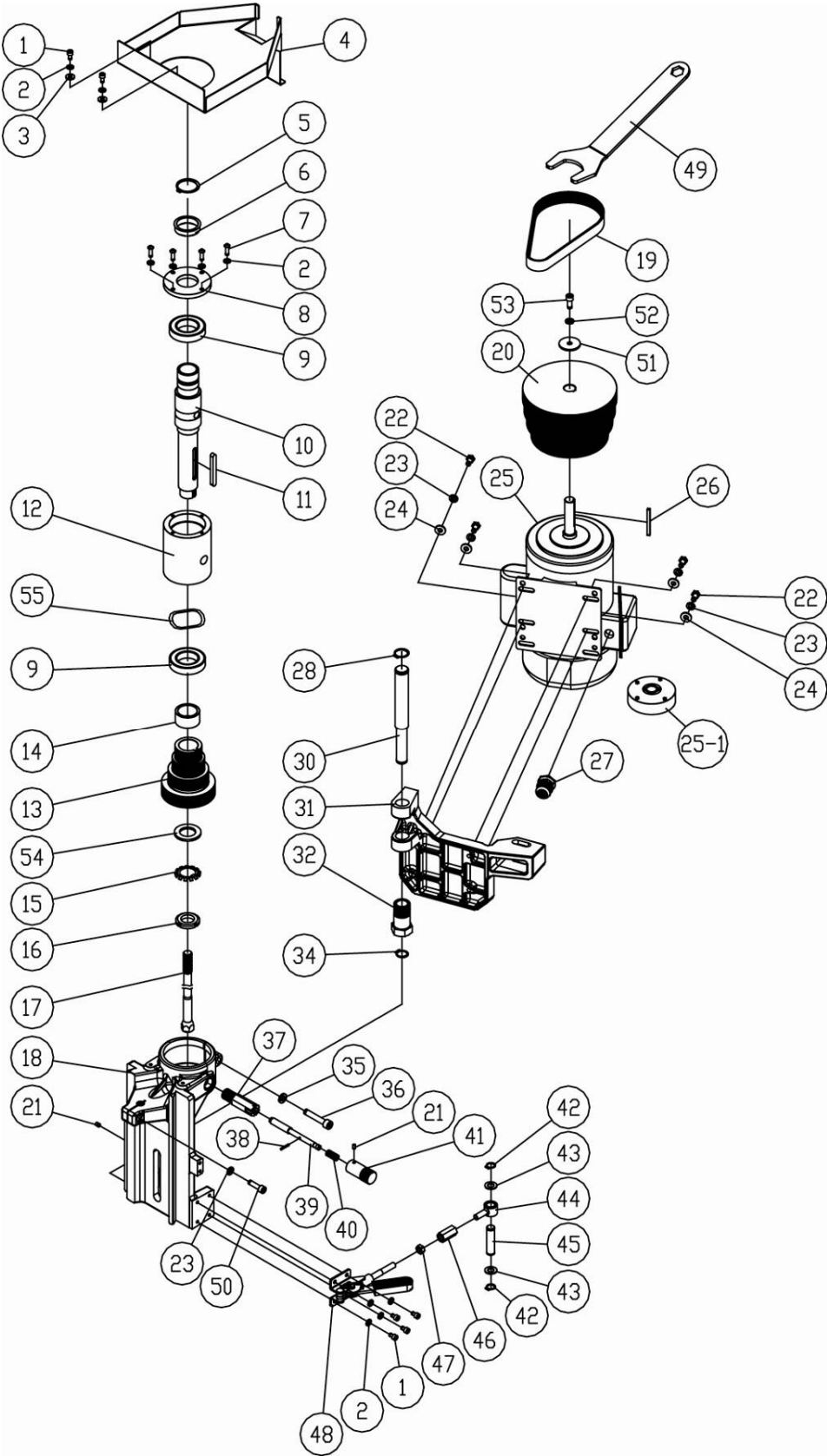

Frame and Motor – Parts List

Index No.	Part No.	Description	Size	Qty
1	TS-1503031	Hex Socket Cap Screw	M6-1.0P x 12	6
2	TS-2361061	Lock Washer	M6	10
3	TS-1550041	Flat Washer	M6	2
4	JWS2700-304	Dust Deflector		1
5	JWS2700-305	S-Ring	STW-40	1
6	JWS2700-306	Upper Bushing		1
7	TS-2246202	Socket HD Button Screw	M6-1.0P x 20	4
8	JWS2700-308	Shaft Top Bearing Cover		1
9	BB-6008VV	Bearing	6008VV	2
10	JWS2700-310	Spindle Holder		1
11	JWS2700-311	Key	8 x 7 x 35	1
12	JWS2700-312	Cartridge		1
13	JWS2700-313	Arbor Pulley		1
14	JWS2700-314	Bushing		1
15	JWS2700-315	Lock Washer	M25	1
16	JWS2700-316	Lock Nut	M25-1.5P	1
17	JWS2700-317	Draw Bar		1
18	JWS2700-318	Spindle Housing		1
19	JWS2700-319	Belt	260J	1
20	JWS2700-320	Motor Pulley		1
21	TS-2276081	Socket Set Screw	M6-1.0P x 8	2
22	TS-1490031	Hex Cap Screw	M8-1.25P x 20	4
23	TS-2361081	Lock Washer	M8	5
24	TS-1550061	Flat Washer	M8	4
25	JWS2700-325AE	Motor	5HP, 50Hz, 400V, 3Ph	1
25-1	JWS2700-325BMAE	Brake Magnet	5HP, 50Hz, 400V, 3Ph	1
	JWS2700-325R	Rectifier (not shown)		1
	JWS2700-325FC	Fan Cover (not shown)		1
	JWS2700-325MF	Motor Fan (not shown)		1
26	JWS2700-326	Key	5 x 5 x 60	1
27	JWS2700-327	Strain Relief Bushing		1
28	JWS2700-328	S-Ring	STW-25	1
30	JWS2700-330	Shaft		1
31	JWS2700-331	Motor Bracket		1
32	JWS2700-332	Adjustment Bolt		1
34	JWS2700-334	S-Ring	STW-20	1
35	TS-2361101	Lock Washer	M10	1
36	JWS2700-336	Hex Socket Cap Screw	M10-1.5P x 55	1
37	JWS2700-337	Connector		1
38	JWS2700-338	Pin	• 3 x 20	1
39	JWS2700-339	Rod		1
40	JWS2700-340	Spring		1
41	JWS2700-341	Knob		1
42	JWS2700-342	S-Ring	STW-15	2
43	JWS2700-343	Flat Washer	M15	2
44	JWS2700-344	Connector		1
45	JWS2700-345	Shaft		1
46	2700-346	Hex Bushing		1
47	TS-1540071	Hex Nut	M10-1.5P	1
48	JWS2700-348	Belt Adjustment Handle		1
49	JWS2700-349	Spindle Nut Wrench		1
50	JWS2700-350	Hex Socket Cap Screw		1
51	JWS2700-351	Special Flat Washer	M8	1
52	TS-1551061	Lock Washer	M8	1
53	TS-1504041	Socket Head Cap Screw	M8 x 20	1
54	JWS2700-354	Flat Washer	M30	1
55	JWS2700-355	Wave Washer		1

Cabinet and Base Assembly

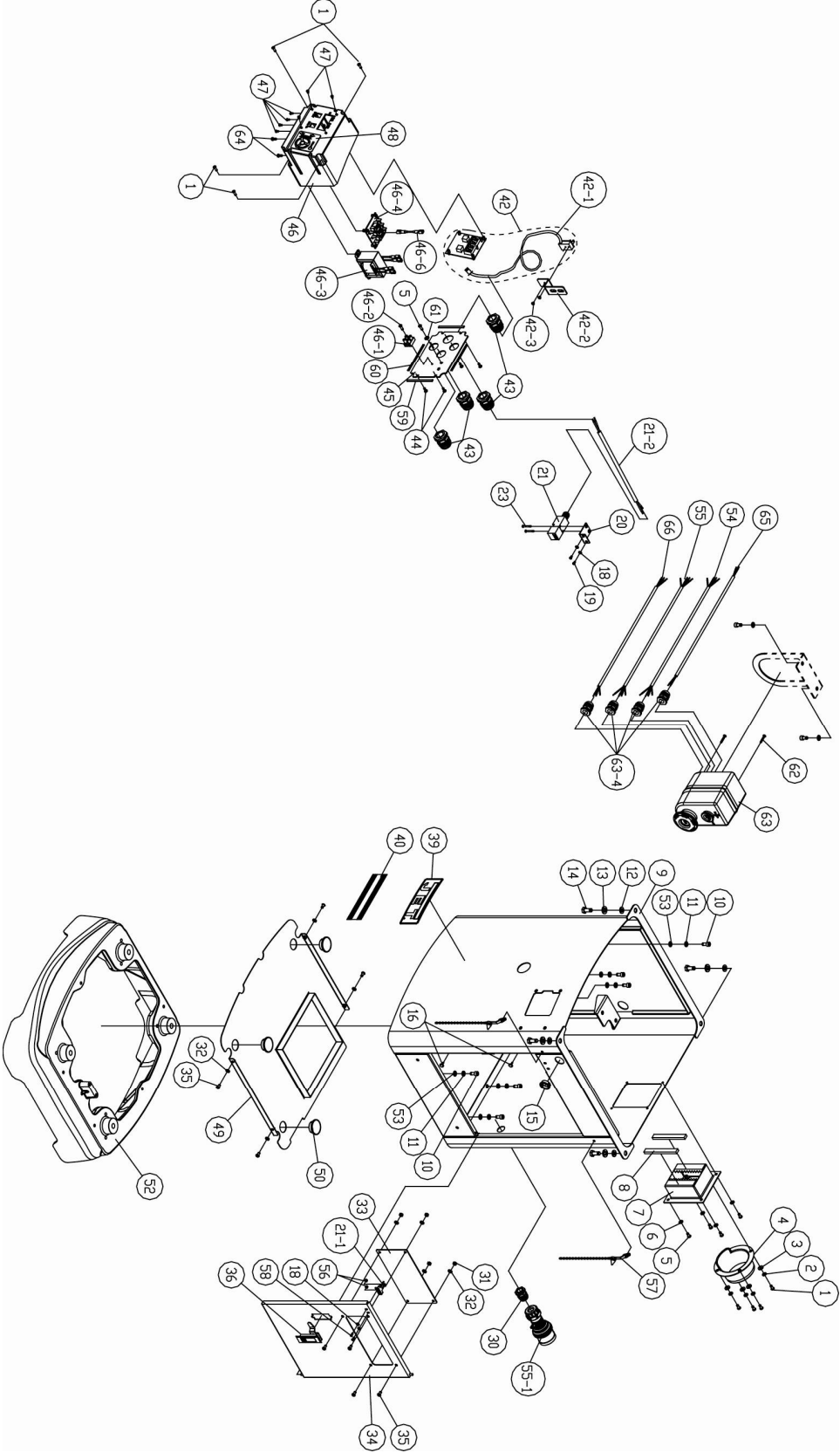

Cabinet and Base – Parts List

Index No.	Part No.	Description	Size	Qty
1	JWS2700-401	Machine Screw	M5-0.8P x 15	8
2	TS-2361051	Lock Washer	M5	4
3	TS-1550031	Flat Washer	M5	4
4	JWS2700-404	Dust Chute		1
5	JWS2700-405	Round Head Cross Screw	M5-0.8P x 10	5
6	TS-2361051	Lock Washer	M5	4
7	JWS2700-407	Dust Deflector		1
8	JWS2700-408	Sponge		2
9	JWS2700-409	Cabinet (w/ truckle)		1
10	TS-1504051	Hex Socket Cap Screw	M8-1.25P x 20	6
11	TS-2361081	Lock Washer	M8	6
12	TS-1550071	Flat Washer	M10	4
13	TS-2361101	Lock Washer	M10	4
14	TS-1491031	Hex Cap Screw	M10-1.5P x 25	4
15	JWS2700-415	Plastic Bushing		1
16	JWS2700-416	Block		2
18	TS-1550021	Flat Washer	M4	4
19	JWS2700-419	Round Head Cross Screw	M4-0.7P x 8	2
20	JWS2700-420	Bracket		1
21	JWS2700-421	Limited Switch	400V,10A	1
21-1	JWS2700-421A	Limited Switch Key		1
21-2	JWS2700-421B	Limited Switch Cable	H05VV-F 1.5mm ² x 2C	1
23	JWS2700-423	Round Head Cross Screw	M4-0.7P x 35	2
30	JWS2700-430	Strain Relief	PG16	1
31	TS-1540041	Hex Nut	M6-1.0P	4
32	TS-2361061	Lock Washer	M6	8
33	JWS2700-433	Window		1
34	JWS2700-434	Door		1
35	JWS2700-435	Round Head Cross Screw	M6-1.0P x 12	8
36	JWS2700-436	Latch		1
39	JWS2700-439	JET Logo		1
40	JWS2700-440	Wide Stripe		1
42	JWS2700-442	Sensor Assembly incl. DRO circuit board		1
42-1	JWS2700-442A	Sensor w/ Sensor Cable	SJT 24AWG x 4C	1
42-2	JWS2700-442B	Sensor Support Bracket		1
42-3	JWS2700-442C	Screw		2
43	JWS2700-443	Strain Relief	PG13.5	4
44	TS-1532042	Machine Screw	M4 x 12	4
45	JWS2700-445	Switch Plate		1
46	JWS2700-446	DRO Cover		1
	JWS2700-446A	DRO Completely Assembly		
		(#1,5,21,23,42,43,44,45,46,47,48,59,60,61 and 64)		1
46-1	JWS2700-446B	Terminal Bracket		1
46-2	JWS2700-446C	Screw	M3 x 0.5P x 12	1
46-3	JWS2700-446C	Transformer	0.5VA, 400V, 5V	1
46-4	JWS2700-446C	Fuse Bracket Incl. Fuses		1
46-5	JWS2700-446D	Fuse (not shown)	0.5A	3
46-6	JWS2700-446E	Wire		1
47	JWS2700-447	Round Head Cross Screw	M3-0.5P x 6	8
48	JWS2700-448	Sticker		1
49	JWS2700-449	Plate (w/o truckle)		1
50	JWS2700-450	Cap		3
52	JWS2700-452	Base (w/o castor)		1
53	TS-1550061	Flat Washer	M8	6

Index No.	Part No.	Description	Size	Qty
54	JWS2700-454	Motor Cable	H05VV-F 1.0mm ² x 4C	1
55	JWS2700-455	Power Cord	H05VV-F 1.0mm ² x 4C	1
55-1	JWS2700-455AE	Plug	3P+N+E,400V,16A,IP44	1
56	TS-1541001	Nylon Lock Nut	M4	2
57	JWS2700-457	Fix up Chain		2
58	TS-2246122	Socket Head Button Screw	M6-1.0P x 12	2
59	JWS2700-459	Dust Cushion (Short)		2
60	JWS2700-460	Dust Cushion (Long)		2
61	JWS2700-461	Start Washer	BW-5	2
62	JWS2700-113	Screw	M5-2.12P x 25	2
63	JWS2700-114AE	Magnetic Switch Completely Assembly	5HP, 50Hz, 400V, 3Ph	1
		(#54, 55, 62, 63, 65 and 66)		1
63-1	JWS2700-114MCAE	Contact (not shown)	400V, max 9A	1
63-2	JWS2700-114OLAE	Overload (not shown)	8-11A	1
63-3	JWS2700-114K	Magnetic Key (not shown)		1
63-4	JWS2700-114ST	Strain Relief	PG13.5	4
64	JWS2700-464	Plastic Screw	M4 x 0.7P x 10	2
65	JWS2700-465	Magnetic Switch Connect to DRO Cable	H05VV-F 1.0mm ² x 3C	1
66	JWS2700-466	Sensor Power Cable	H05VV-F 1.0mm ² x 2C	1

Elevator Assembly

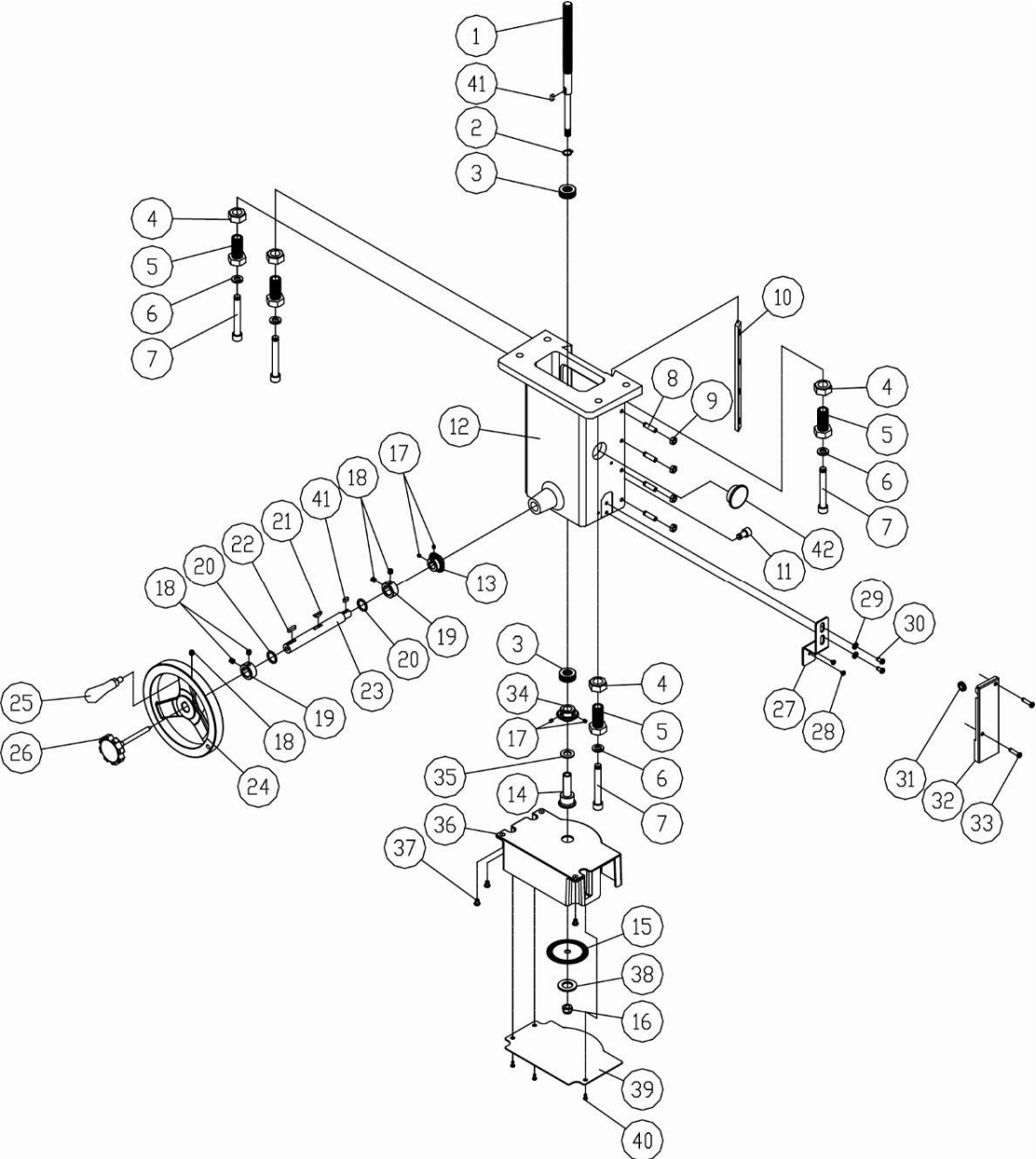

Elevator – Parts List

Index No.	Part No.	Description	Size	Qty
1	JWS2700-501	Lead Screw		1
2	JWS2700-342	S-Ring	STW-15	1
3	JWS2700-503	Support Bearing	51202	2
4	TS-2310201	Hex Nut	M20-1.5P	4
5	JWS2700-505	Adjusting Bolt		4
6	TS-2361121	Lock Washer	M12	4
7	TS-1506141	Hex Socket Cap Screw	M12-1.75P x 90	4
8	JWS2700-508	Socket Set Screw	M8-1.25P x 30	4
9	TS-2311081	Hex Nut	M8	4
10	JWS2700-510	Gib		1
11	TS-1505021	Hex Socket Cap Screw	M10-1.5P x 20	1
12	JWS2700-512	Support		1
13	JWS2700-513	Worm Gear (Right rotation)		1
14	JWS2700-514	Bushing		1
15	JWS2700-515	Sensor Plate		1
16	TS-1541041	Nylon Nut	M10-1.25P	1
17	JWS2700-517	Socket Set Screw	M5-0.8P x 5	4
18	TS-0270021	Socket Set Screw	5/16"-18 x 5/16"	5
19	JWS2700-519	Fix Ring		2
20	JWS2700-520	Flat Washer	M19	2
21	JWS2700-521	Key		1
22	JWS2700-522	Key	5 x 5 x 20	1
23	JWS2700-523	Lead Screw		1
24	JWS2700-524	Hand Wheel		1
25	JWS2700-525	Handle		1
26	JWS2700-526	Knob		1
27	JWS2700-527	Bracket		1
28	JWS2700-528	Round Head Cross Screw	M3-1.06P x 6	2
29	TS-2361061	Lock Washer	M6	2
30	TS-2286122	Round Head Cross Screw	M6-1.0P x 12	2
31	JWS2700-531	Strain Relief		1
32	JWS2700-532	Plate		1
33	JWS2700-533	Screw	M6-1.0P x 25	2
34	JWS2700-534	Worm Gear (Left rotation)		1
35	TS-1550071	Flat Washer	M10	1
36	JWS2700-536	Cover		1
37	JWS2700-537	Screw	M6-1.0P x 12	3
38	JWS2700-538	Flat Washer		1
39	JWS2700-539	Plate		1
40	JWS2700-540	Screw	M6-1.0P x 25	3
41	JWS2700-541	Key	5 x 5 x 12	2
42	JWS2700-542	Cap		1

Caster Assembly

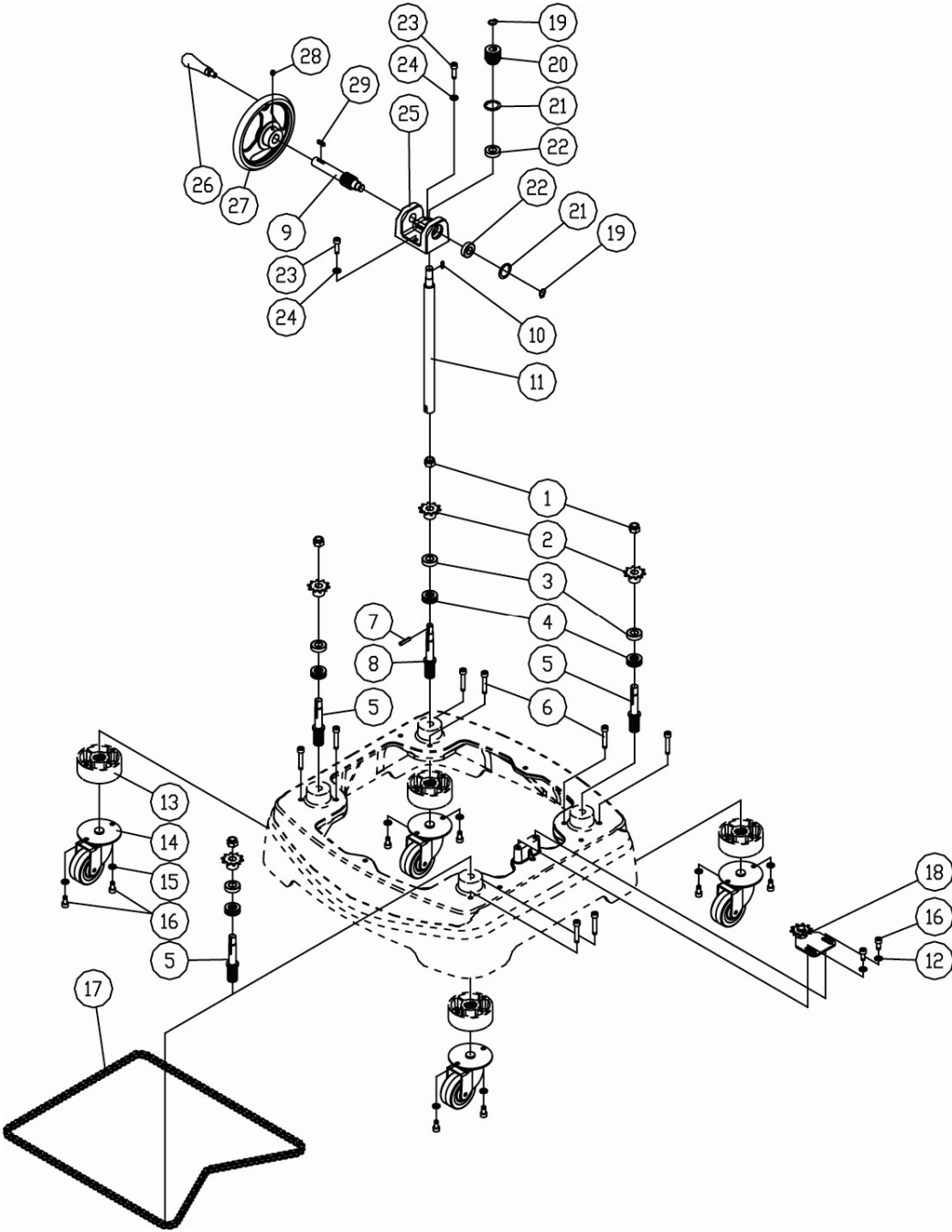

Caster – Parts List

Index No.	Part No.	Description	Size	Qty
1	PM2700-601	Nylon Nut	M14-2.0P	4
2	PM2700-602	Sprocket		4
3	BB-6002ZZ	Ball Bearing		4
4	PM2700-503	Thrust Bearing	51202	4
5	PM2700-605	Shaft		3
6	TS-1504101	Hex Socket Cap Screw	M8-1.25P x 50	8
7	PM2700-607	Spring Pin	• 5 x 32	1
8	PM2700-608	Lead Shaft		1
9	PM2700-609	Gear Shaft		1
10	PM2700-610	Key	4 x 4 x 16	1
11	PM2700-611	Lead Screw		1
12	TS-1550061	Flat Washer	M8	2
13	PM2700-613	Elevating Block		4
14	PM2700-614	Castor		4
15	TS-2361081	Lock Washer	M8	8
16	TS-1504041	Hex Socket Cap Screw	M8-1.25P x 20	10
17	PM2700-617	Chain		1
18	PM2700-618	Sprocket Bracket		1
19	PM2700-342	S-Ring	STW-15	2
20	PM2700-620	Gear		1
21	PM2700-621	R-Ring	RTW-32	2
22	BB-6002ZZ	Ball Bearing		2
23	TS-1504061	Hex Socket Cap Screw	M8-1.25P x 30	2
24	TS-1550061	Flat Washer	M8	2
25	PM2700-625	Bracket		1
26	PM2700-626	Handle		1
27	PM2700-627	Handle Wheel		1
28	TS-0270021	Socket Set Screw	5/16"-18 x 5/16"	1
29	PM2700-629	Key	5 x 5 x 20	1

Spindle Assembly 30mm (Standard Equipment)

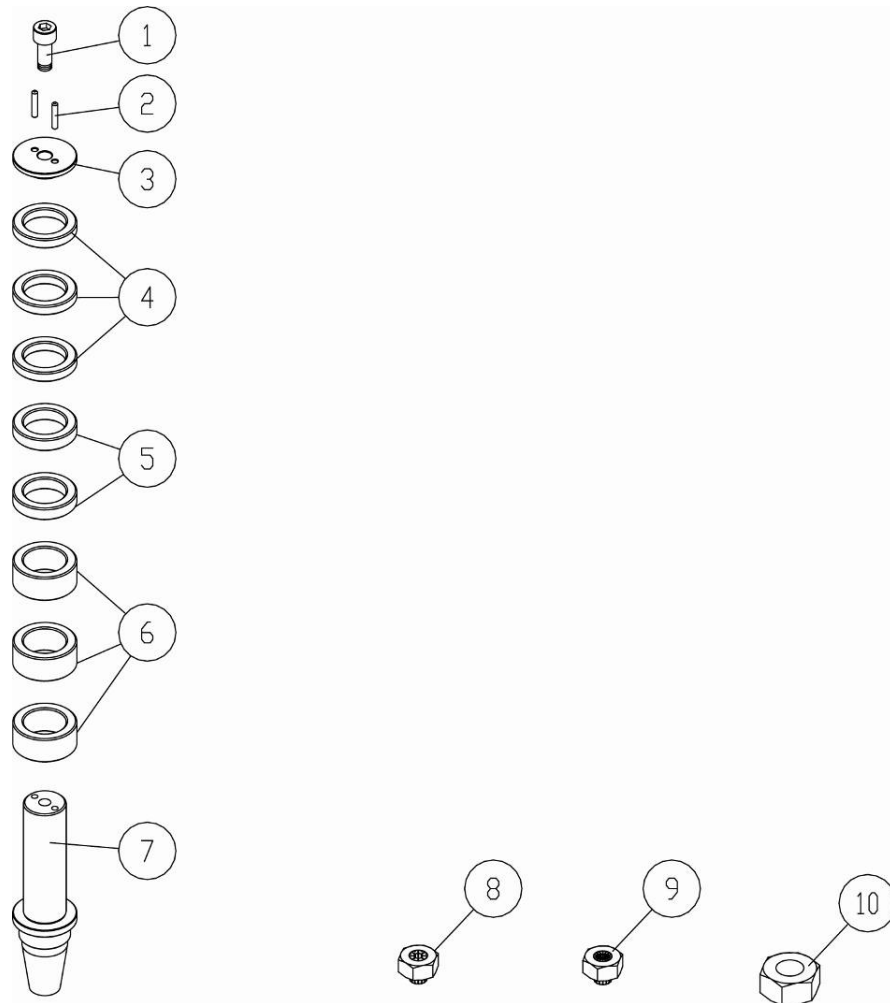

Index No.	Part No.	Description	Size	Qty
1	TS-1505041	Socket Head Cap Screw	M10-1.5P x 30	1
2	JWS2700-702	Pin	• 4 x 25	2
3	JWS2700-703	Special Washer		1
4	JWS2700-704	Collar	30 x 8mmT	3
5	JWS2700-705	Collar	30 x 10mmT	2
6	JWS2700-706	Collar	30 x 20mmT	3
7	JWS2700-707	Arbor	30mm	1
	JWS2700-707A	Arbor Assembly (#1 thru #7 and #10)	30mm	1
8	JWS2700-708	Collet	8mm	1
9	JWS2700-709	Collet	12mm	1
10	JWS2700-710	Arbor Nut	M40x2.5p	1

Spindle Assembly for 35mm/40mm/50mm (Optional Equipment)

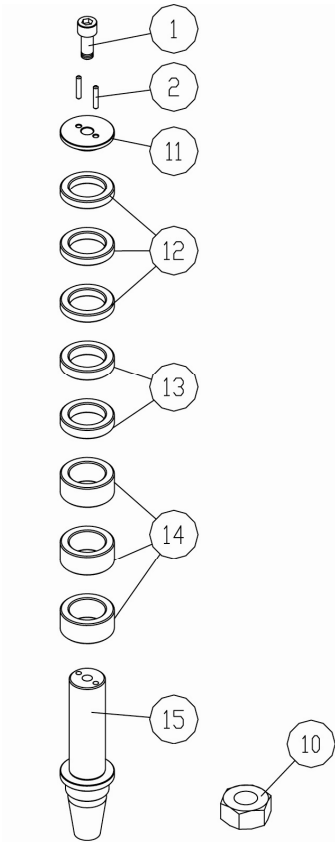

35mm Spindle

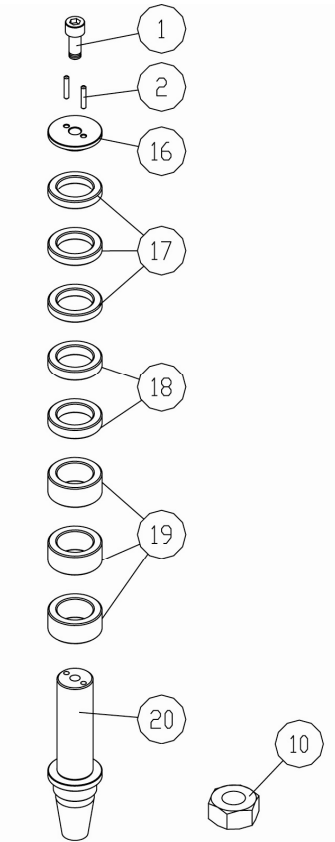

40mm Spindle

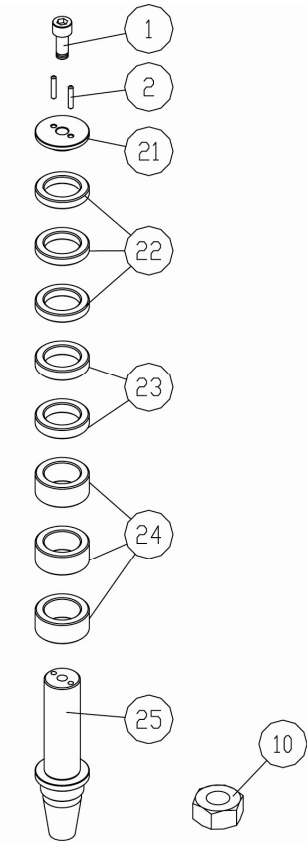

50mm Spindle

Optional Spindle Assembly– Parts List (35mm)

Index No.	Part No.	Description	Size	Qty
1	TS-1505041	Socket Head Cap Screw	M10-1.5P x 30	1
2	JWS2700-702	Pin	• 4 x 25	2
10	JWS2700-710	Arbor Nut	M40x2.5p	1
11	JWS2700-811	Special Washer		1
12	JWS2700-812	Collar	35 x 8mmT	3
13	JWS2700-813	Collar	35 x 10mmT	2
14	JWS2700-814	Collar	35 x 20mmT	3
15	JWS2700-815	Arbor	35mm	1
	JWS2700-815A	Arbor Assembly (#1, 2, #10 thru #15)	35mm	1

Optional Spindle Assembly – Parts List (40mm)

Index No.	Part No.	Description	Size	Qty
1	TS-1505041	Socket Head Cap Screw	M10-1.5P x 30	1
2	JWS2700-702	Pin	• 4 x 25	2
10	JWS2700-710	Arbor Nut	M40x2.5p	1
16	JWS2700-816	Special Washer		1
17	JWS2700-817	Collar	40 x 8mmT	3
18	JWS2700-818	Collar	40 x 10mmT	2
19	JWS2700-819	Collar	40 x 20mmT	3
20	JWS2700-820	Arbor	40mm	1
	JWS2700-820A	Arbor Assembly (#1, 2 #10, #16 thru #20)	40mm	1

Optional Spindle Assembly – Parts List (50mm)

Index No.	Part No.	Description	Size	Qty
1	TS-1505041	Socket Head Cap Screw	M10-1.5P x 30	1
2	JWS2700-702	Pin	• 4 x 25	2
10	JWS2700-710	Arbor Nut	M40x2.5p	1
21	JWS2700-821	Special Washer		1
22	JWS2700-822	Collar	50 x 8mmT	3
23	JWS2700-823	Collar	50 x 10mmT	2
24	JWS2700-824	Collar	50 x 20mmT	3
25	JWS2700-825	Arbor	50mm	1
	JWS2700-825A	Arbor Assembly (#1, 2 #10, #21 thru #25)	50mm	1

JWS-2700
1280102T

400/50/3

	colour of strands	Litzenfarben	couleur des cordons
BK	black	schwarz	noir
WH	white	weiß	blanc
BU	blue	blau	bleu
YE	yellow	gelb	jaune
RD	red	rot	rouge
BN	brown	braun	brun
GY	grey	grau	gris
GNYE	green-yellow	grün-gelb	vert-jaune
OG	orange	orange	orange
VT	violet	violett	violet

	meaning of symbol	Bedeutung der Zeichen	interprétation
M	motor	Motor	moteur
S	switch	Schalter	interrupteur
Fu	fuse	Sicherung	fusible
R	rectifier	Gleichrichter	rectifier
BR	motor break	Motorbremse	frein de moteur
TR	Transformer	Transformator	Transformateur
OL	overload cut-off	Überlastschuttschalter	déclencheur surcharge
LS	limit switch	Positionsendschalter	micro
KM	contactor for main motor	Hauptschütz	contacteur moteur
DRO	Digital read out	Digitalanzeige	indication numérique

